

User's Manual

IE-V850E-MC, IE-V850E-MC-A

In-Circuit Emulator

Target Devices

V850E1 (NB85E Core)

V850E/MA1™

V850E/MA2™

V850E/SV2™

V850E/IA1™

V850E/IA2™

[MEMO]

V850 Series, V850E/MA1, V850E/MA2, V850E/SV2, V850E/IA1, and V850E/IA2 are trademarks of NEC Electronics Corporation.

Windows is either a trademark or a registered trademark of Microsoft Corporation in the United States and/or other countries.

PC/AT is a trademark of International Business Machines Corporation.

Ethernet is a trademark of Xerox Corporation.

- **The information in this document is current as of March, 2003. The information is subject to change without notice. For actual design-in, refer to the latest publications of NEC Electronics data sheets or data books, etc., for the most up-to-date specifications of NEC Electronics products. Not all products and/or types are available in every country. Please check with an NEC Electronics sales representative for availability and additional information.**

- No part of this document may be copied or reproduced in any form or by any means without the prior written consent of NEC Electronics. NEC Electronics assumes no responsibility for any errors that may appear in this document.

- NEC Electronics does not assume any liability for infringement of patents, copyrights or other intellectual property rights of third parties by or arising from the use of NEC Electronics products listed in this document or any other liability arising from the use of such products. No license, express, implied or otherwise, is granted under any patents, copyrights or other intellectual property rights of NEC Electronics or others.

- Descriptions of circuits, software and other related information in this document are provided for illustrative purposes in semiconductor product operation and application examples. The incorporation of these circuits, software and information in the design of a customer's equipment shall be done under the full responsibility of the customer. NEC Electronics assumes no responsibility for any losses incurred by customers or third parties arising from the use of these circuits, software and information.

- While NEC Electronics endeavors to enhance the quality, reliability and safety of NEC Electronics products, customers agree and acknowledge that the possibility of defects thereof cannot be eliminated entirely. To minimize risks of damage to property or injury (including death) to persons arising from defects in NEC Electronics products, customers must incorporate sufficient safety measures in their design, such as redundancy, fire-containment and anti-failure features.

- NEC Electronics products are classified into the following three quality grades: "Standard", "Special" and "Specific".

The "Specific" quality grade applies only to NEC Electronics products developed based on a customer-designated "quality assurance program" for a specific application. The recommended applications of an NEC Electronics product depend on its quality grade, as indicated below. Customers must check the quality grade of each NEC Electronics product before using it in a particular application.

"Standard": Computers, office equipment, communications equipment, test and measurement equipment, audio and visual equipment, home electronic appliances, machine tools, personal electronic equipment and industrial robots.

"Special": Transportation equipment (automobiles, trains, ships, etc.), traffic control systems, anti-disaster systems, anti-crime systems, safety equipment and medical equipment (not specifically designed for life support).

"Specific": Aircraft, aerospace equipment, submersible repeaters, nuclear reactor control systems, life support systems and medical equipment for life support, etc.

The quality grade of NEC Electronics products is "Standard" unless otherwise expressly specified in NEC Electronics data sheets or data books, etc. If customers wish to use NEC Electronics products in applications not intended by NEC Electronics, they must contact an NEC Electronics sales representative in advance to determine NEC Electronics' willingness to support a given application.

(Note)

(1) "NEC Electronics" as used in this statement means NEC Electronics Corporation and also includes its majority-owned subsidiaries.

(2) "NEC Electronics products" means any product developed or manufactured by or for NEC Electronics (as defined above).

Regional Information

Some information contained in this document may vary from country to country. Before using any NEC Electronics product in your application, please contact the NEC Electronics office in your country to obtain a list of authorized representatives and distributors. They will verify:

- Device availability
- Ordering information
- Product release schedule
- Availability of related technical literature
- Development environment specifications (for example, specifications for third-party tools and components, host computers, power plugs, AC supply voltages, and so forth)
- Network requirements

In addition, trademarks, registered trademarks, export restrictions, and other legal issues may also vary from country to country.

[GLOBAL SUPPORT]

<http://www.necel.com/en/support/support.html>

NEC Electronics America, Inc. (U.S.)
Santa Clara, California
Tel: 408-588-6000
800-366-9782

NEC Electronics (Europe) GmbH
Duesseldorf, Germany
Tel: 0211-65 03 01

NEC Electronics Hong Kong Ltd.
Hong Kong
Tel: 2886-9318

- **Sucursal en España**
Madrid, Spain
Tel: 091-504 27 87

NEC Electronics Hong Kong Ltd.
Seoul Branch
Seoul, Korea
Tel: 02-558-3737

- **Succursale Française**
Vélizy-Villacoublay, France
Tel: 01-30-67 58 00

NEC Electronics Shanghai, Ltd.
Shanghai, P.R. China
Tel: 021-6841-1138

- **Filiale Italiana**
Milano, Italy
Tel: 02-66 75 41

NEC Electronics Taiwan Ltd.
Taipei, Taiwan
Tel: 02-2719-2377

- **Branch The Netherlands**
Eindhoven, The Netherlands
Tel: 040-244 58 45

NEC Electronics Singapore Pte. Ltd.
Novena Square, Singapore
Tel: 6253-8311

- **Tyskland Filial**
Taebby, Sweden
Tel: 08-63 80 820

- **United Kingdom Branch**
Milton Keynes, UK
Tel: 01908-691-133

Major Revisions in This Edition

Page	Description
Throughout	<ul style="list-style-type: none"> • Addition of V850E/MA2, V850E/SV2, and V850E/IA2 as target devices • Addition of IE-70000-PCI-IF-A as corresponding PC interface board • Modification of IE-V850E-MC-A shape
p.11	1.1 Hardware Configuration <ul style="list-style-type: none"> • Addition of IE-703166-MC-EM1 and IE-703114-MC-EM1 as option boards • Addition of SWEX-xxxSD-1 as extension probe
p.13	1.3 Function Specifications <ul style="list-style-type: none"> • Thorough modification
P.13 in the previous edition	Deletion of 1.4 Hardware Configuration
p.14	1.4 System Configuration <ul style="list-style-type: none"> • Addition of SWEX-xxxSD-1 as extension probe • Addition of descriptions about connector configurations
p.17	1.6.1 When using IE-V850E-MC-A on a standalone basis for performing software debugging <ul style="list-style-type: none"> • Addition and modification of descriptions
p.18	1.6.2 When performing hardware debugging with target system <ul style="list-style-type: none"> • Addition and modification of descriptions
p.21	2.2 Pod Part Names and Functions <ul style="list-style-type: none"> • Thorough modification
p.24	3.1.3 Insertion of PC interface board <ul style="list-style-type: none"> • Addition and modification of descriptions
p.25	3.2 Connection to Target System <ul style="list-style-type: none"> • Modification of descriptions in (1) • Figure 3-1 Connection of Connector for Target Connection and Connector for Emulator Connection divided according to target device
p.31	3.3.1 Power adapter connection <ul style="list-style-type: none"> • Addition of description to Caution
p.32	3.3.4 Additional information <ul style="list-style-type: none"> • Addition of description to procedure
p.33	3.4.1 Power-on procedure <ul style="list-style-type: none"> • Modification of procedure
p.33	3.4.2 Power-off procedure <ul style="list-style-type: none"> • Modification of procedure
p.34	Addition of CHAPTER 4 SHIPMENT SETTINGS
p.36	Addition of APPENDIX B REVISION HISTORY

The mark ★ shows major revised points.

INTRODUCTION

Target Readers This manual is intended for users who design and develop application systems using V850E1, V850E/MA1, V850E/MA2, V850E/SV2, V850E/IA1, and V850E/IA2 microcontrollers.

Purpose Debugging can be performed efficiently with these emulators (IE-V850E-MC, IE-V850E-MC-A) connected to a dedicated option board when designing and developing application systems using V850E1, V850E/MA1, V850E/MA2, V850E/SV2, V850E/IA1, and V850E/IA2 microcontrollers.
The purpose of this manual is to describe the proper operation of the IE-V850E-MC and IE-V850E-MC-A and their basic specifications.

Organization This manual is broadly divided into the following parts.

- Overview
- Connection of parts
- Names and functions of parts
- Shipment settings

How to Read This Manual It is assumed that the reader of this manual has general knowledge in the fields of electrical engineering, logic circuits, and microcontrollers.

To learn about the basic specifications and operation
→Read this manual in the order listed in **CONTENTS**.

To learn the operation methods, command functions, etc., of the IE-V850E-MC or IE-V850E-MC-A
→Read the user's manual of the debugger (sold separately) that is used.

Conventions

Note: Footnote for item marked with **Note** in the text

Caution: Information requiring particular attention

Remark: Supplementary information

Numeral representation: Binary ... xxxx or xxxxB
Decimal ... xxxx
Hexadecimal ... xxxxH

Prefix representing a power of 2 (address space, memory capacity):
K (kilo): $2^{10} = 1024$
M (mega): $2^{20} = 1024^2$

Terminology The meanings of terms used in this manual are listed below.

Target device	This is the device to be emulated.
Target system	The system (user-built system) to be debugged. This includes the target program and hardware configured by the user.
Emulation CPU	Device that performs emulation of the target device in the IE-V850E-MC, IE-V850E-MC-A.

Product Name in This Manual In this manual, unless otherwise specified, the IE-V850E-MC-A is treated as the representative model. When this manual is used as the IE-V850E-MC manual, replace IE-V850E-MC-A with IE-V850E-MC.
For the functional differences between the IE-V850E-MC and the IE-V850E-MC-A, refer to **CHAPTER 1 OVERVIEW**.

Related Documents When using this manual, refer to the following manuals.
The related documents (user's manuals) indicated in this publication may include preliminary versions. However, preliminary versions are not marked as such.

Documents Related to Development Tools (User's Manuals)

Document Name		Document Number
V850E1 Architecture		U14559E
V850E/MA1 Hardware		U14359E
V850E/MA2 Hardware		U14980E
V850E/IA1 Hardware		U14492E
V850E/IA2 Hardware		U15195E
V850E/SV2 Hardware		U16384E
IE-V850E-MC, IE-V850E-MC-A (In-Circuit Emulator)		This manual
IE-703107-MC-EM1 (In-Circuit Emulator Option Board)		U14481E
IE-703114-MC-EM1 (In-Circuit Emulator Option Board)		To be prepared
IE-703116-MC-EM1 (In-Circuit Emulator Option Board)		U14700E
IE-703166-MC-EM1 (In-Circuit Emulator Option Board)		To be prepared
IE-V850E-MC-EM1-A (In-Circuit Emulator)		To be prepared
IE-V850E-MC-EM1-B, IE-V850E-MC-MM2 (In-Circuit Emulator Option Board)		U14482E
V850 Series™ Development Tools (Supporting 32-Bit OS) Windows™ Based (Application Note)	Tutorial Guide	U16544E
CA850 Ver.2.50 C Compiler Package	Operation	U16053E
	C Language	U16054E
	Assembly Language	U16042E
PM plus Ver.5.10		U16559E
ID850 Ver.2.50 Integrated Debugger	Operation Windows based	U16217E
SM850 Ver.2.50 System Simulator	Operation Windows based	U16218E
RX850 Ver.3.13 or Later (Real-Time OS)	Basics	U13430E
	Installation	U13410E
	Technical	U13431E
RX850 Pro Ver.3.13 (Real-Time OS)	Basics	U13773E
	Installation	U13774E
	Technical	U13772E
RD850 (Task Debugger) ^{Note}		U11158E
RD850 Ver.3.01 Task Debugger		U13737E
RD850 Pro Ver.3.01 Task Debugger		U13916E
AZ850 Ver.3.10 System Performance Analyzer		U14410E
PG-FP4 Flash Memory Programmer		U15260E

Note ID850 (Ver.1.31 only) supported

CONTENTS

CHAPTER 1 OVERVIEW	10
1.1 Hardware Configuration	11
1.2 Features.....	12
1.3 Function Specifications.....	13
1.4 System Configuration	14
1.5 Contents in Carton	15
1.6 Setup.....	17
1.6.1 When using the IE-V850E-MC-A on a stand-alone basis for performing software debugging	17
1.6.2 When performing hardware debugging with target system	18
CHAPTER 2 PART NAMES AND FUNCTIONS.....	19
2.1 Main Unit Part Names and Functions.....	20
2.2 Pod Part Names and Functions	21
CHAPTER 3 CONNECTION OF COMPONENTS	23
3.1 Connection to Personal Computer.....	23
3.1.1 Overview of connection	23
3.1.2 Connection procedure	23
3.1.3 Insertion of PC interface board.....	24
3.1.4 Connection of PC interface cable	24
3.2 Connection to Target System	25
3.3 Cable Connections.....	31
3.3.1 Power adapter connection.....	31
3.3.2 PC interface cable connection.....	31
3.3.3 External logic probe connection	32
3.3.4 Additional information	32
3.4 System Power-On and Power-Off.....	33
3.4.1 Power-on procedure	33
3.4.2 Power-off procedure	33
★ CHAPTER 4 SHIPMENT SETTINGS.....	34
APPENDIX A DIMENSIONS	35
★ APPENDIX B REVISION HISTORY.....	36

LIST OF FIGURES

Figure No.	Title	Page
1-1	System Configuration (QFP Package).....	14
1-2	Contents in Carton.....	15
1-3	Accessories	16
2-1	IE-V850E-MC-A	19
2-2	Main Unit	20
2-3	Pod (Top View).....	21
2-4	Pod (Bottom View).....	22
3-1	Connecting to Target System	25
3-2	Direction Marking for Pin 1 of Connector (Top View)	29
3-3	Connection of IE-V850E-MC-A to Target System	30
3-4	Power Adapter Connection.....	31
3-5	PC Interface Cable Connection	31
3-6	External Logic Probe Connection (Using IC Clip).....	32

CHAPTER 1 OVERVIEW

The IE-V850E-MC-A and IE-V850E-MC are in-circuit emulators that are used to efficiently debug hardware and software during the development of systems that employ the V850E1, V850E/MA1, V850E/MA2, or V850E/SV2, and the V850E/IA1 or V850E/IA2, respectively.

They incorporate functions such as a break/trace function using events, a coverage function for program performance evaluation, and a timer/counter function.

To perform debugging, the option board (sold separately) corresponding to the relevant device product must be connected.

The IE-V850E-MC is an in-circuit emulator for $V_{DD} = 5.0$ V.

The IE-V850E-MC-A is an in-circuit emulator for $V_{DD} = 3.3$ V.

1.1 Hardware Configuration

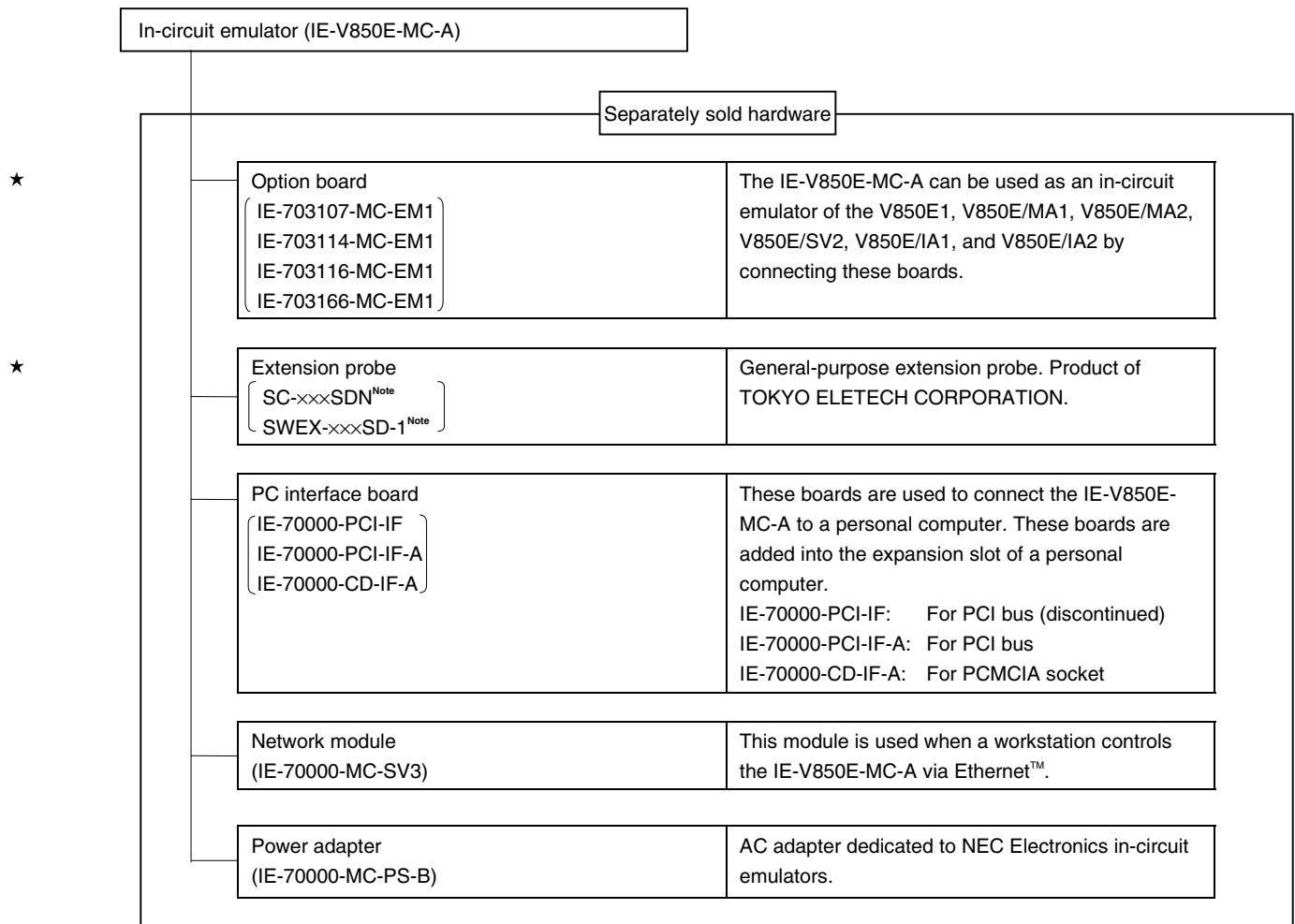

Note For further information, contact Daimaru Kogyo., Ltd.
Tokyo Electronic Components Division (TEL +81-3-3820-7112)
Osaka Electronic Components Division (TEL +81-6-6244-6672)

Caution Be aware that, depending on the operating frequency of the emulator, use of an extension probe may cause abnormal operation.

1.2 Features

- Maximum operating frequency: 50 MHz (at $V_{DD} = 3.3\text{ V}, 5.0\text{ V}$)
- Extremely lightweight and compact
- Higher equivalence with target device can be achieved by omitting buffer between signal cables
- The following pins can be masked
RESET, NMI, WAIT, HLDRQ
- The dimensions and environmental conditions for operation are as follows

Parameter		Value
Maximum operating frequency		50 MHz
Supply voltage (DC)		5 V
Operating voltage (DC)		$V_{DD} = 3.3\text{ V}$ (IE-V850E-MC-A), 5.0 V (IE-V850E-MC)
Power consumption		11 W (operating frequency: 50 MHz) ^{Note}
External dimensions (Refer to APPENDIX A DIMENSIONS)	Height	56 mm
	Length	353 mm
	Width	90 mm
Weight		500 g
Operating temperature range		0 to 40°C
Storage temperature range		0 to 45°C
Ambient humidity range		10 to 80% RH

Note The power consumption is 11.4 W when the option board is connected to the IE-V850E-MC-A.

★ 1.3 Function Specifications

Item		Specification
Emulation memory capacity	Internal ROM	1 MB (max.)
	External memory	Note
Execution/pass detection (coverage memory capacity)		1 MB (max.)
Program execution function	Real-time execution function	Go, Execution from cursor position, Automatic Go, Execution up to cursor position, Restart, Return out
	Non-real-time execution function	Step-in, next over, slow-motion
Break function		Event detection break, software break, forced break, break via come function, break on condition met during step execution, failsafe break
Trace function	Trace condition	All trace, section trace, qualify trace
	Memory capacity	168 bits × 32 K frames
Other functions		Mapping function, event function, coverage measurement function, snapshot function, stub function, register manipulation function, memory manipulation function, time measurement function, real-time RAM sampling function

Note External emulation memory is not mounted on the IE-V850E-MC-A. External emulation memory is mounted on the separately-sold option board, so refer to the option board user's manual.

Caution Some of the functions may not be supported depending on the debugger used.

1.4 System Configuration

The system configuration when connecting the option board to the IE-V850E-MC-A, which is then connected to a personal computer (PC-9800 series, PC/AT™ or compatible) is illustrated below.

- ★ The connector configuration varies depending on the target device. For details, refer to the user's manual of the option board.

Figure 1-1. System Configuration (QFP Package)

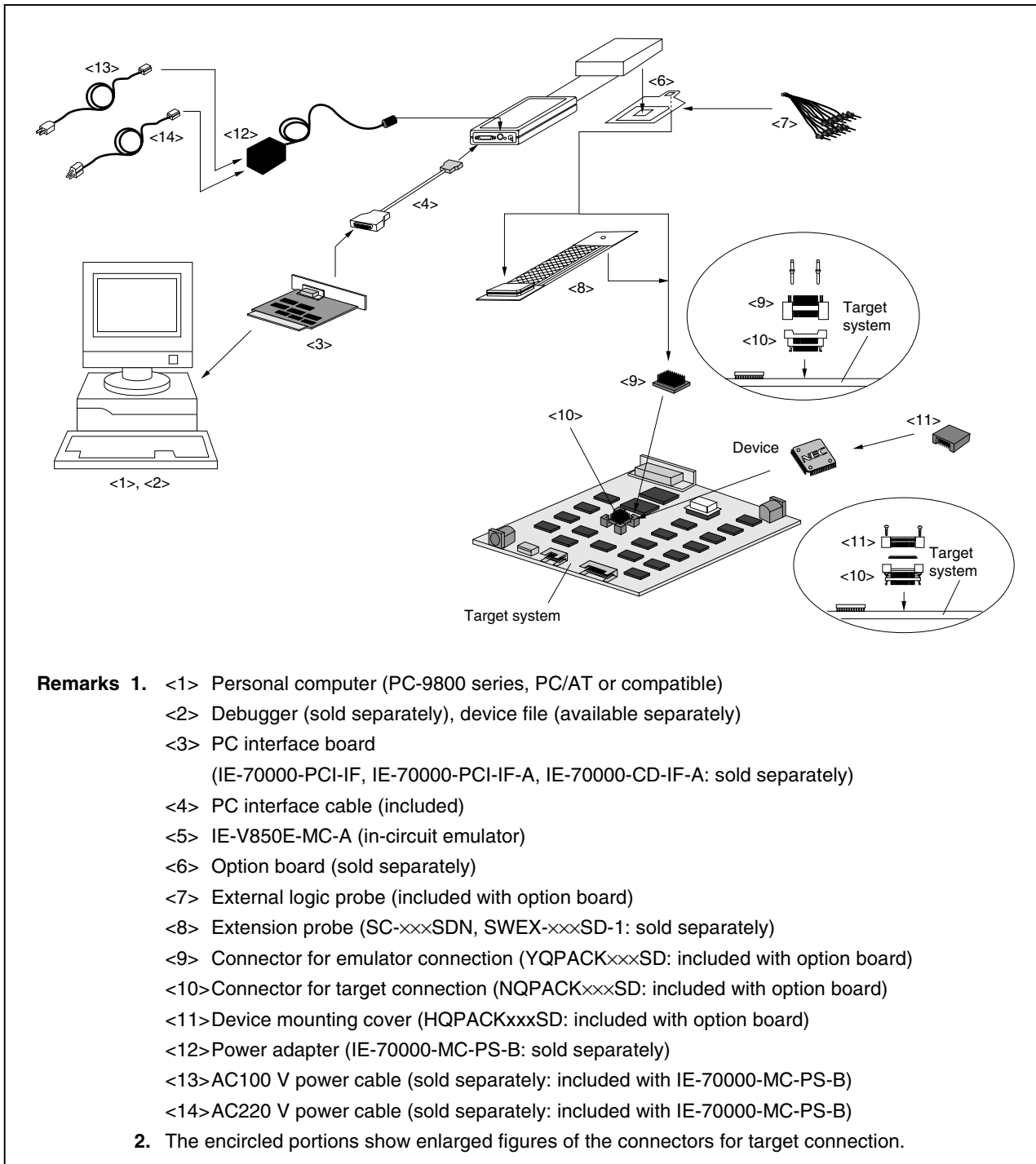

1.5 Contents in Carton

The carton of the IE-V850E-MC-A contains a main unit, guarantee card, packing list, and accessory bag.

Make sure that the accessory bag includes this manual and cables. In case of missing or damaged contents, please contact an NEC Electronics sales representative or distributor.

Figure 1-2. Contents in Carton

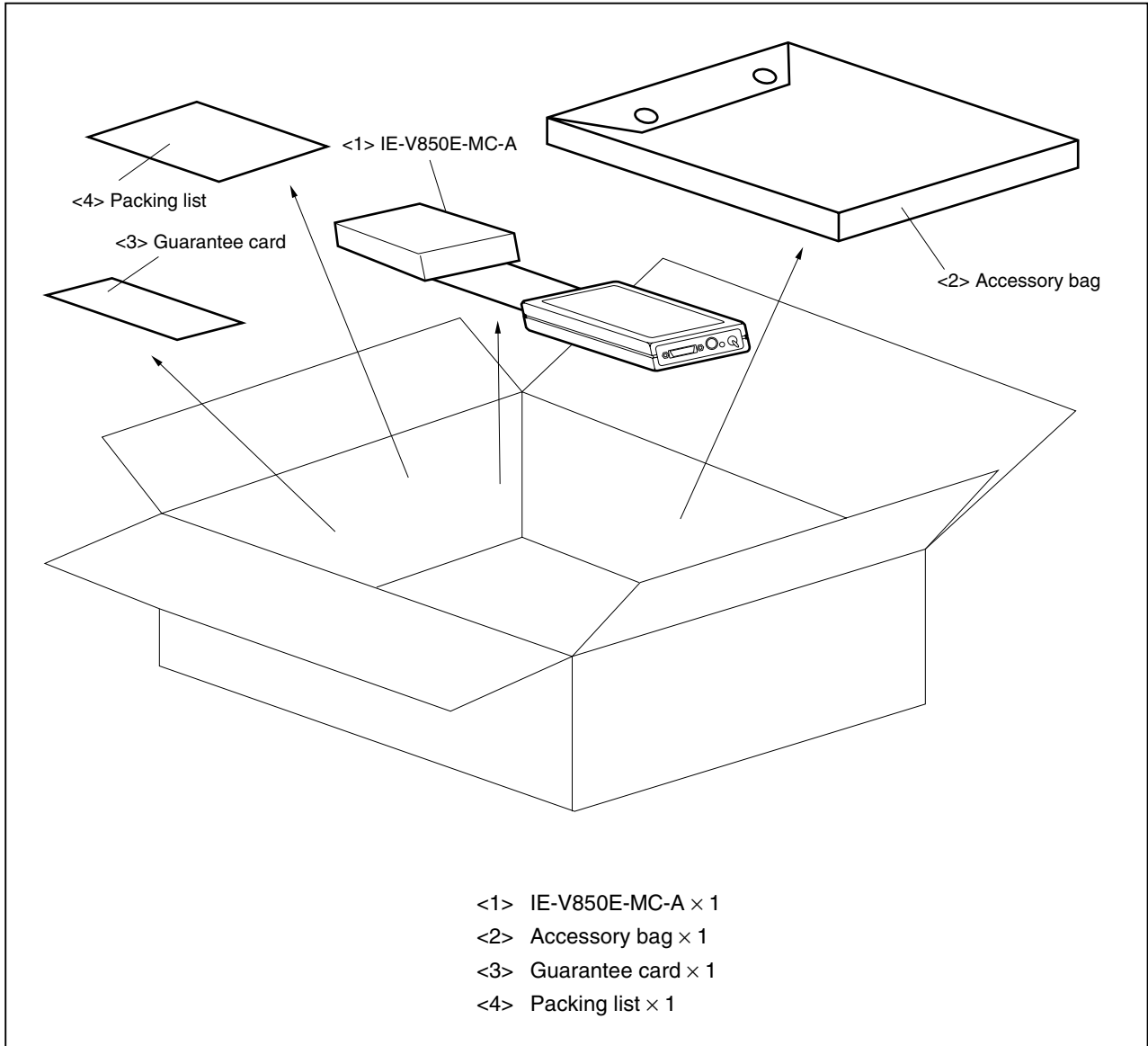

Check that the accessory bag contains this manual, an accessory list, and the following accessories.

- (a) PC interface cable × 2 (for the IE-70000-PCI-IF, IE-70000-PCI-IF-A × 1, for the IE-70000-CD-IF-A × 1)
- (b) Plastic spacer × 2 sets
(including 2 plastic screws and 2 washers)
- (c) Nylon rivet × 4

Figure 1-3. Accessories

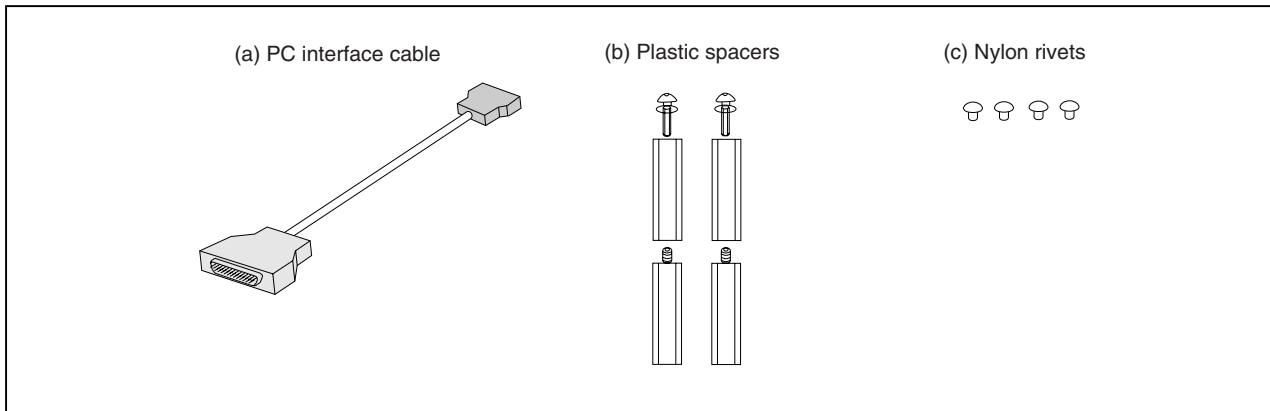

1.6 Setup

The following two system configurations for the IE-V850E-MC-A are possible, depending on the purpose. This section describes the setup procedure according to each purpose as follows.



★ 1.6.1 When using the IE-V850E-MC-A on a standalone basis for performing software debugging

- | | | |
|-----|-------------------------------|-------------------------------------|
| (1) | Connect interface board to PC | 3.1 Connection to Personal Computer |
|-----|-------------------------------|-------------------------------------|

Before connecting, make sure that the power of the PC is off (when using PCI bus).

- | | | |
|-----|---|--|
| (2) | Connect option board | Refer to the user's manual of the option board |
| (3) | Set clock operation mode of IE-V850E-MC-A | Refer to the user's manual of the option board |
| (4) | Set CPU operating voltage range | Refer to the user's manual of the option board |

Switch CPU operating voltage range.

- | | | |
|-----|----------------|-----------------------|
| (5) | Connect cables | 3.3 Cable Connections |
|-----|----------------|-----------------------|

Connect power source adapter and interface cable.

- | | | |
|-----|------------------------|-----------------------------------|
| (6) | Power up IE-V850E-MC-A | 3.4 System Power-On and Power-Off |
| (7) | Start debugger | 3.4 System Power-On and Power-Off |

★ 1.6.2 When performing hardware debugging with target system

Caution Before turning on the power of the target system, make sure that the power of the IE-V850E-MC-A is turned on. If the target system is turned on while the IE-V850E-MC-A is off, the target system or the IE-V850E-MC-A may be damaged.

- (1)

Connect interface board to PC

 —

3.1 Connection to Personal Computer

Before connecting, make sure that the power of the PC is off (when using PCI bus).

- (2)

Connect option board

 —

Refer to the user's manual of the option board
--

- (3)

Set clock operation mode of IE-V850E-MC-A

 —

Refer to the user's manual of the option board
--

- (4)

Set CPU operating voltage range

 —

Refer to the user's manual of the option board
--

Switch CPU operating voltage range.

- (5)

Connect cables

 —

3.3 Cable Connections

Connect power source adapter and interface cable.

- (6)

Connect IE-V850E-MC-A to target system
--

 —

3.2 Connection to Target System

There are two connection methods: connecting the connection tab of the option board to the target system directly, and connecting the connection tab of the option board to the target system via an extension probe (sold separately).

- (7)

Power up IE-V850E-MC-A, then target system
--

 —

3.4 System Power-On and Power-Off

- (8)

Start debugger

 —

3.4 System Power-On and Power-Off

CHAPTER 2 PART NAMES AND FUNCTIONS

This chapter describes the name and function of each part of the IE-V850E-MC-A, as well as switch settings.

Figure 2-1. IE-V850E-MC-A

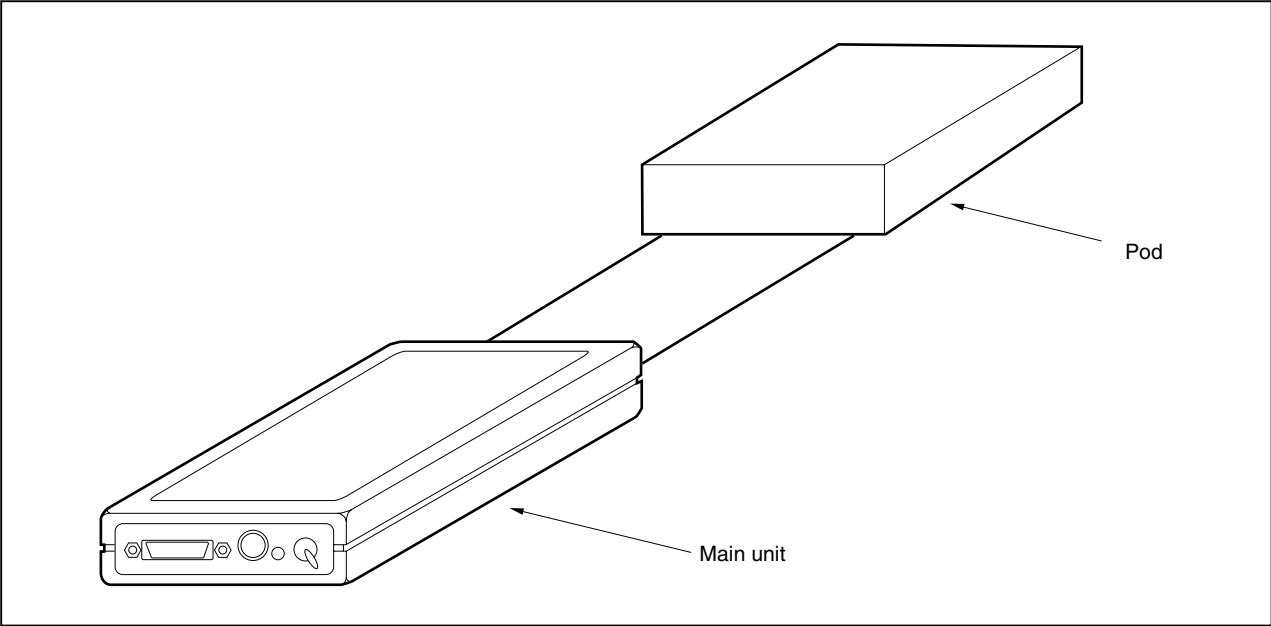

2.1 Main Unit Part Names and Functions

Figure 2-2. Main Unit

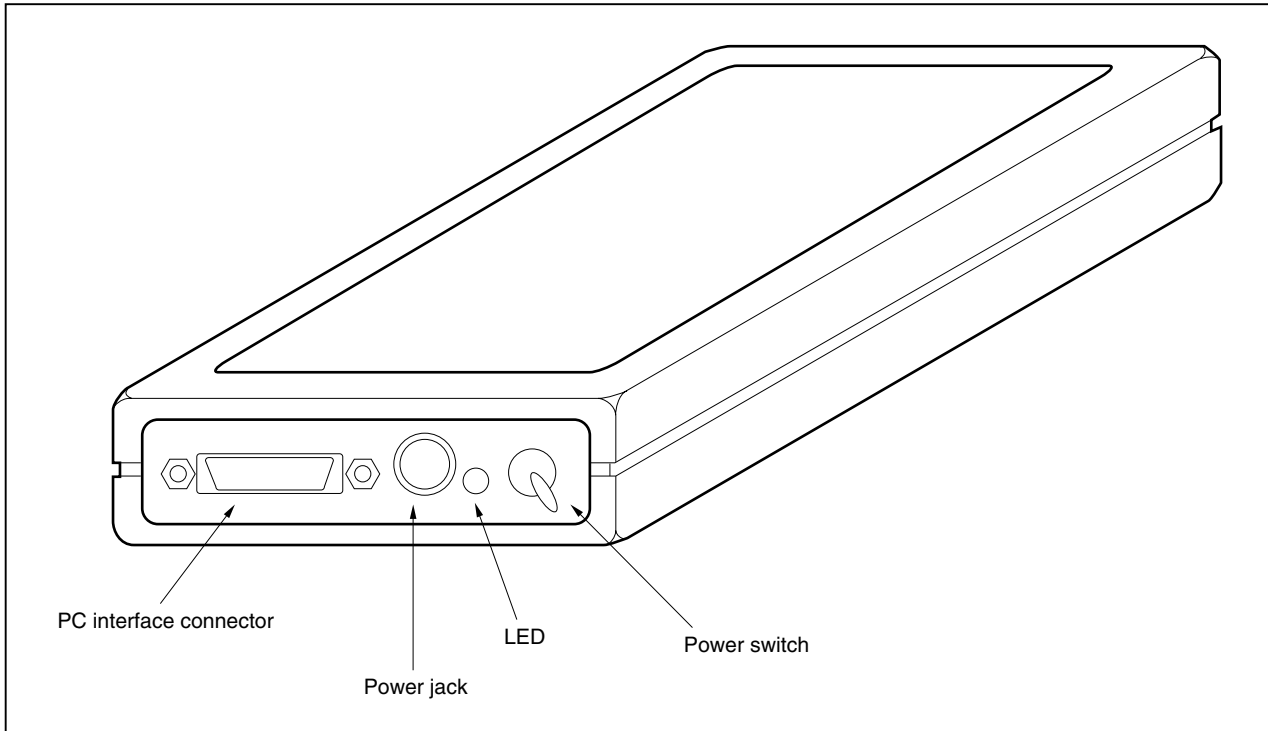

(1) Power switch

This is the main power ON/OFF switch of the IE-V850E-MC-A.
The ON/OFF direction is printed on the chassis of the main part.

(2) Power jack

A power adapter (IE-70000-MC-PS-B: sold separately) is connected here.

(3) PC interface connector

The PC interface cable (included) is connected here.

(4) LED

Lit when the power is on, extinguished when the power is off.

★ 2.2 Pod Part Names and Functions

Figure 2-3. Pod (Top View)

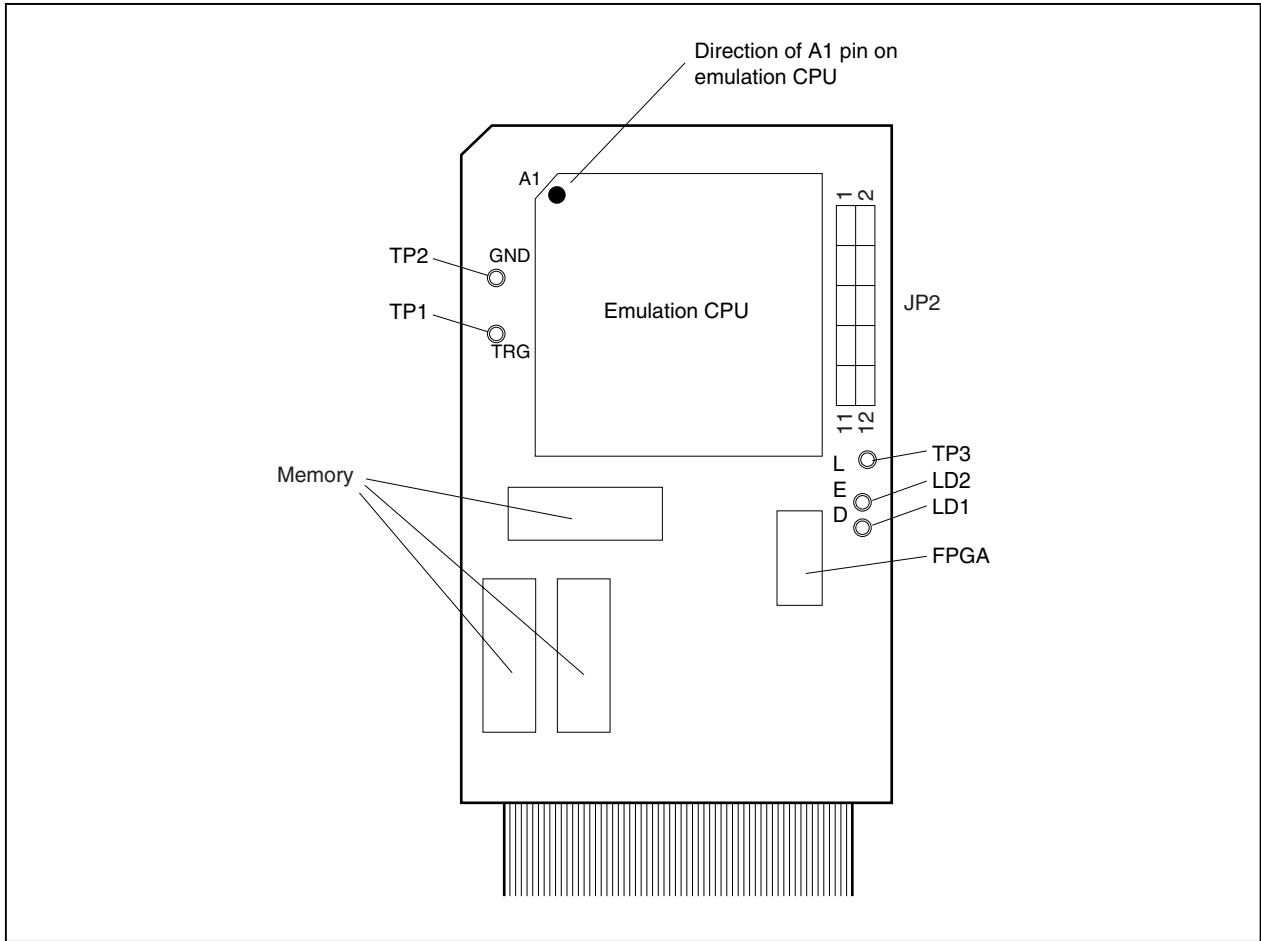

(1) Test pins

- TP1: For shipment test
- TP2: Ground
- TP3: Ground

(2) JP2

The setting varies depending the option board to be set. For how to set, refer to the manual of the option board (unless specified, use this jumper with the shipment setting. After shipment, the jumper is set with 1 and 2 shorted and 7 and 8 shorted).

(3) LD1, LD2

Name	Status	Description
LD1 (red)	On	Switch of main unit = On
	Off	Switch of main unit = Off
LD2 (amber)	On	Power supply of target system = On
	Off	Power supply of target system = Off

Figure 2-4. Pod (Bottom View)

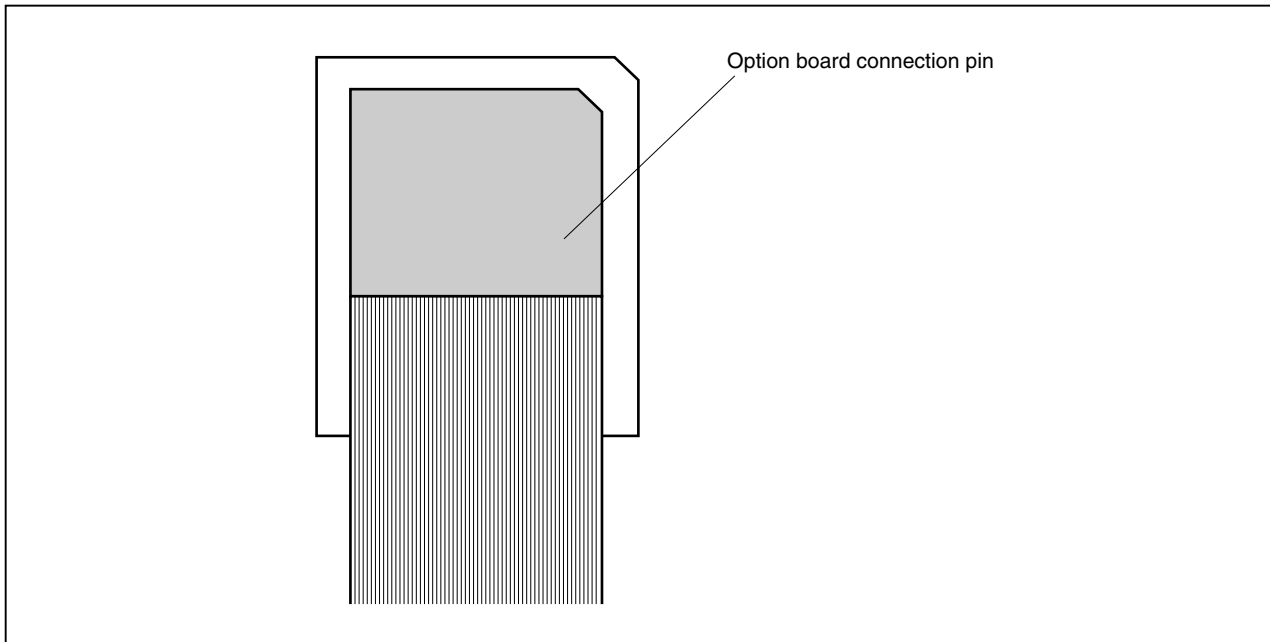

(1) Option board connection pin

Connect this pin to the PGA socket on the option board (sold separately) side.

CHAPTER 3 CONNECTION OF COMPONENTS

The IE-V850E-MC-A enables debugging and programming of target devices by connecting several components and configuring the desired system.

This chapter describes the various components and their connection. Read this chapter when connecting system components. For the sequence of system configuration, refer to **1.6 Setup**.

For details of software startup, refer to the user's manual of the debugger that is used.

3.1 Connection to Personal Computer

3.1.1 Overview of connection

The IE-V850E-MC-A can use a personal computer (PC-9800 series, or PC/AT compatible) as the host machine. The connection to each type of personal computer is described below.

(1) Desktop PC

When using a desktop PC, insert the following PC interface board in the external expansion slot of the desktop PC and connect the computer to the IE-V850E-MC-A.

- IE-70000-PCI-IF, IE-70000-PCI-IF-A: For PCI bus (can also be used in a PC98-NX series and PC/AT or compatible)

(2) Notebook-type personal computer

When using a notebook-type personal computer, insert the PC card interface (IE-70000-CD-IF-A: sold separately) in the PC card slot of the computer and connect the computer to the IE-V850E-MC-A.

3.1.2 Connection procedure

(1) Powering off

Perform connection while the power of each unit is off.

If the power of the IE-V850E-MC-A or the PC is on, turn off the power first.

(2) PC interface board setting

When the IE-70000-PCI-IF and IE-70000-PCI-IF-A are shipped, an 8-bit connector board is premounted. However, when the IE-V850E-MC-A is connected, this must be changed to a 32-bit connector board.

The 32-bit connector board is supplied with the IE-70000-PCI-IF and IE-70000-PCI-IF-A. For details, refer to the IE-70000-PCI-IF, IE-70000-PCI-IF-A User's Manual (to be prepared).

★ **3.1.3 Insertion of PC interface board**

Mount the PC interface board on the PC following the instructions described in the user's manual of the PC. When connecting the IE-70000-PCI-IF or IE-70000-PCI-IF-A, turn off the power to the PC first.

3.1.4 Connection of PC interface cable

Connect the PC interface cable to the interface board connector.

★ 3.2 Connection to Target System

There are two connection methods: connecting the connection tab of the option board to the target system directly and connecting the connection tab of the option board to the target system via an extension probe.

- (1) Connect the connectors to the target system. The connection methods vary depending on the target device, so connect as shown in the figures below.

Figure 3-1. Connecting to Target System (1/5)

- (a) When the target device is the V850E/MA1 (QFP package), V850E/IA1, V850E/IA2 (GC package)

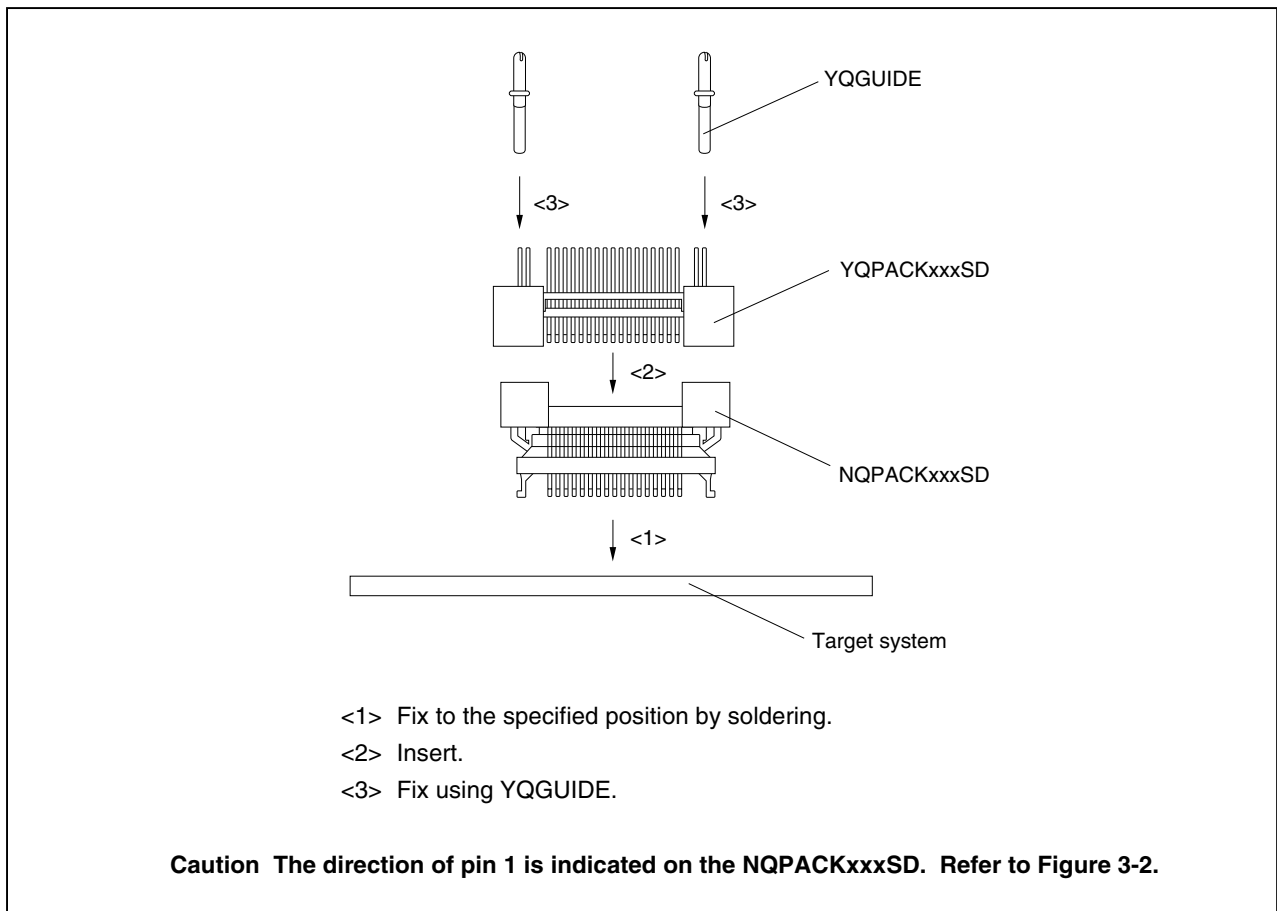
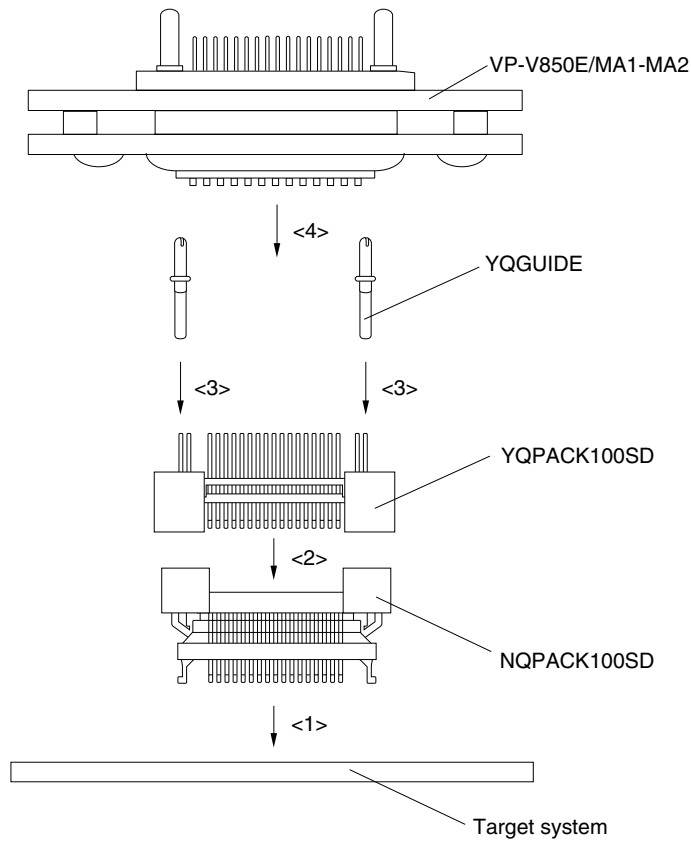

Figure 3-1. Connecting to Target System (2/5)

(b) When the target device is the V850E/MA2



- <1> Fix to the specified position by soldering.
- <2> Insert.
- <3> Fix using YQGUIDE.
- <4> Insert the VP-V850E/MA1-MA2.

Caution The direction of pin 1 is indicated on the NQPACK100SD. Refer to Figure 3-2.

Figure 3-1. Connecting to Target System (3/5)

(c) When the target device is the V850E/IA2 (GF package)

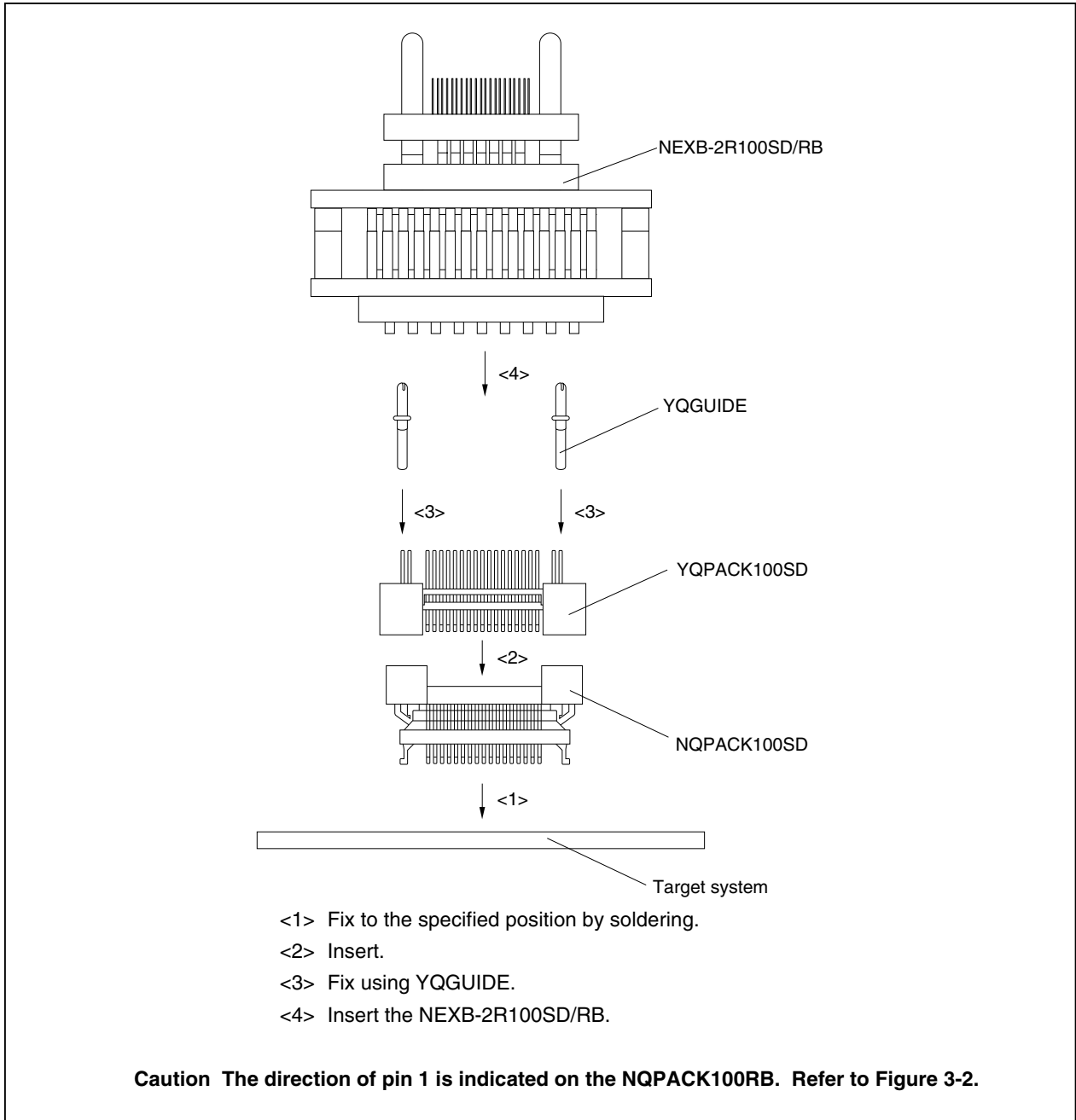
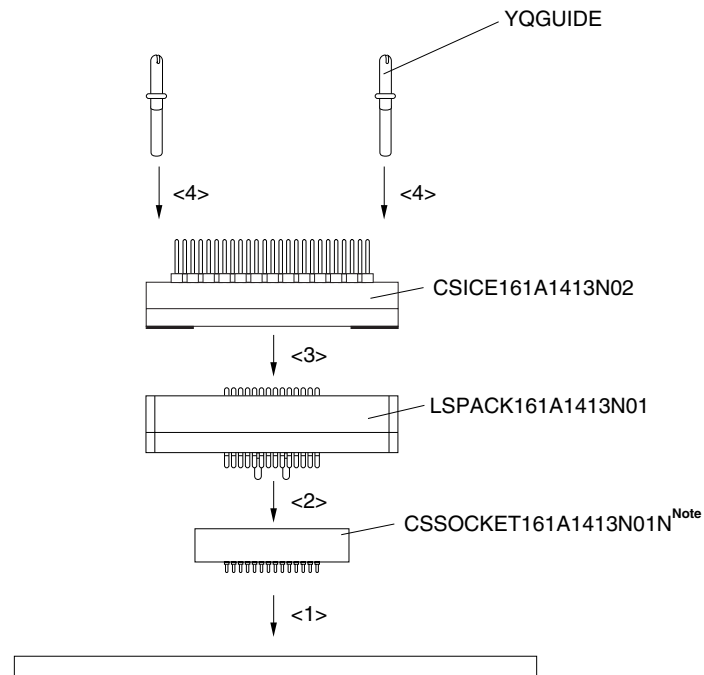

Figure 3-1. Connecting to Target System (4/5)

(d) When the target device is the V850E/MA1 (BGA package)



- <1> Fix to the specified position by soldering.
 (Align the misinsertion prevention pins of both the CSSOCKET and the target system sides.)
- <2> Insert LSPACK in CSSOCKET.
- <3>, <4> Fix CSICE using YQGUIDE.

Caution The target connection connector is a guideless type. If a guide is required, use the part whose part number is not suffixed with N.

Figure 3-1. Connecting to Target System (5/5)

(e) When the target device is the V850E/SV2

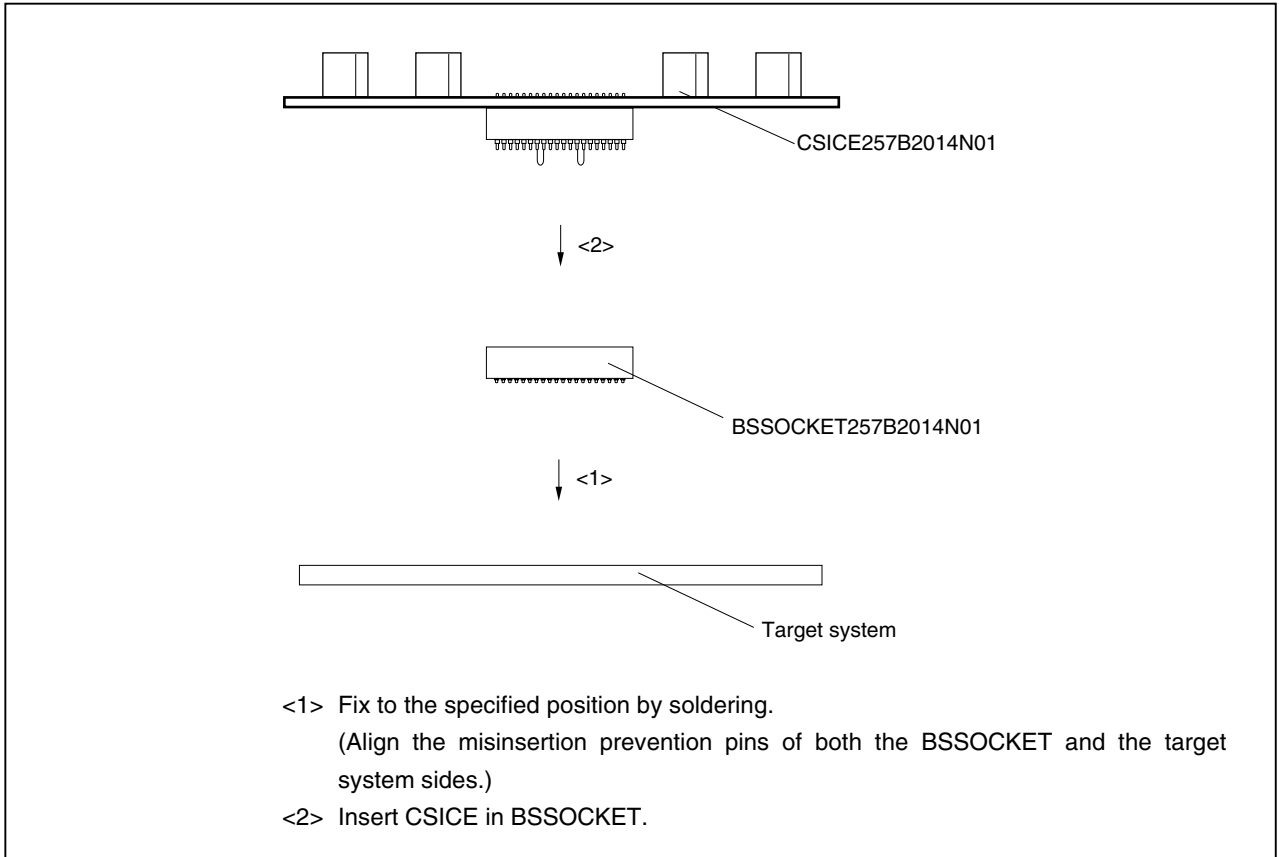
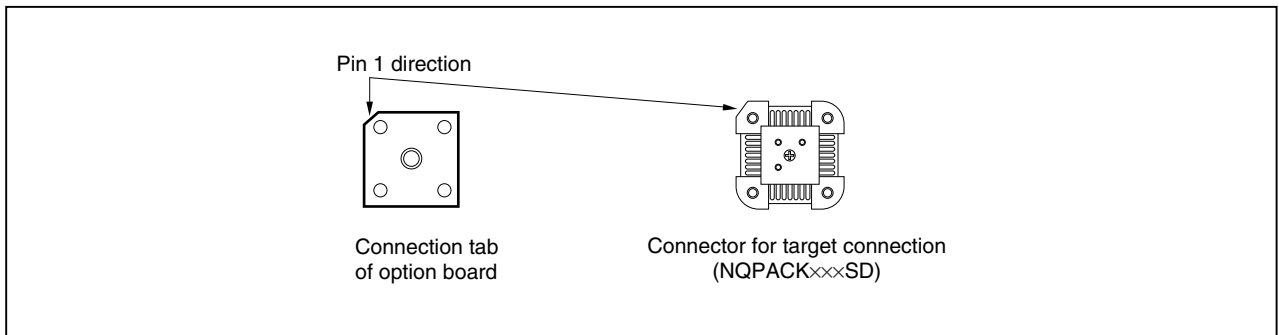

Figure 3-2. Direction Marking for Pin 1 of Connector (Top View)



- (2) Connect the connection tab of the option board to the target system directly or via the extension probe. In either case, make sure that the pin 1 position (cutout corner of connector) is aligned. The connection procedure is as follows.

Caution Be careful not to break or bend the pins of connector, socket, and extension probe when connecting.

(a) When connecting to target system directly

- <1> Turn off the power of the IE-V850E-MC-A (power switch OFF).
- <2> Connect the IE-V850E-MC-A to the option board.
- <3> Connect the connection tab of the option board to the target system.

(b) When connecting to target system via extension probe

- <1> Turn off the power of the IE-V850E-MC-A (power switch OFF).
- <2> Connect the IE-V850E-MC-A to the option board.
- <3> Connect the extension probe to the option board.
- <4> Connect the top of the extension probe to the target system.

Figure 3-3. Connection of IE-V850E-MC-A to Target System

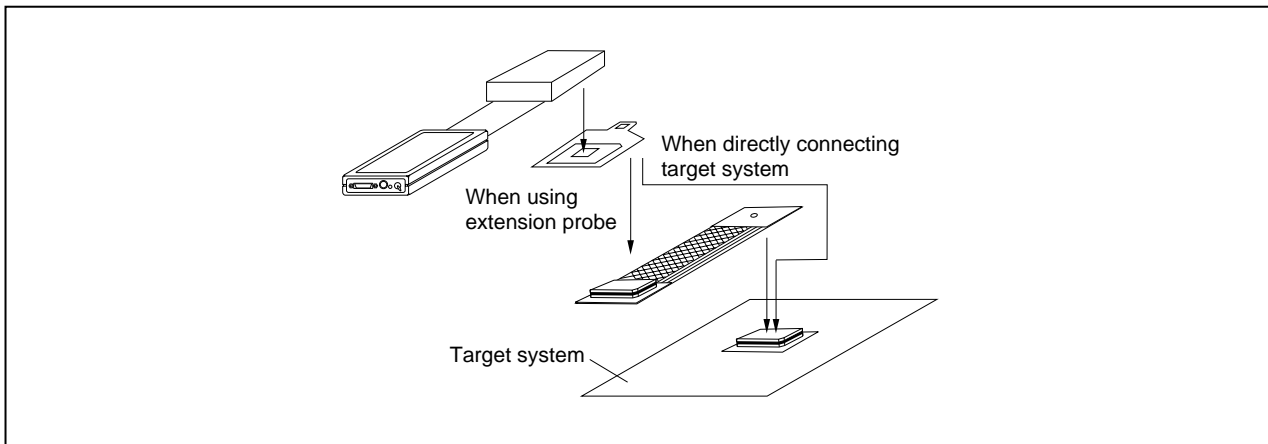

3.3 Cable Connections

3.3.1 Power adapter connection

Insert the cable of the power supply adapter (IE-70000-MC-PS-B: sold separately) to the power jack of the IE-V850E-MC-A main unit.

- ★ **Caution** Use only the IE-70000-MC-PS-B for supplying power. Use of other power supplies may damage the IE-V850E-MC-A due to differences in the power jack polarity, voltage, and power supply capacitance.

Figure 3-4. Power Adapter Connection

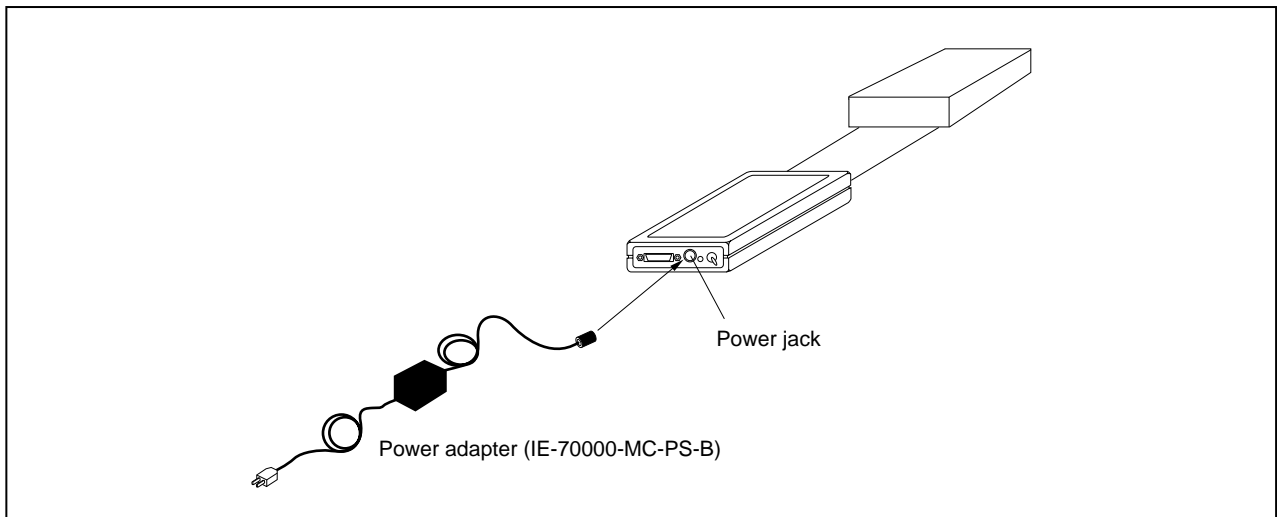

3.3.2 PC interface cable connection

Connect the PC interface cable to the PC interface connector of the IE-V850E-MC-A main unit.

Figure 3-5. PC Interface Cable Connection

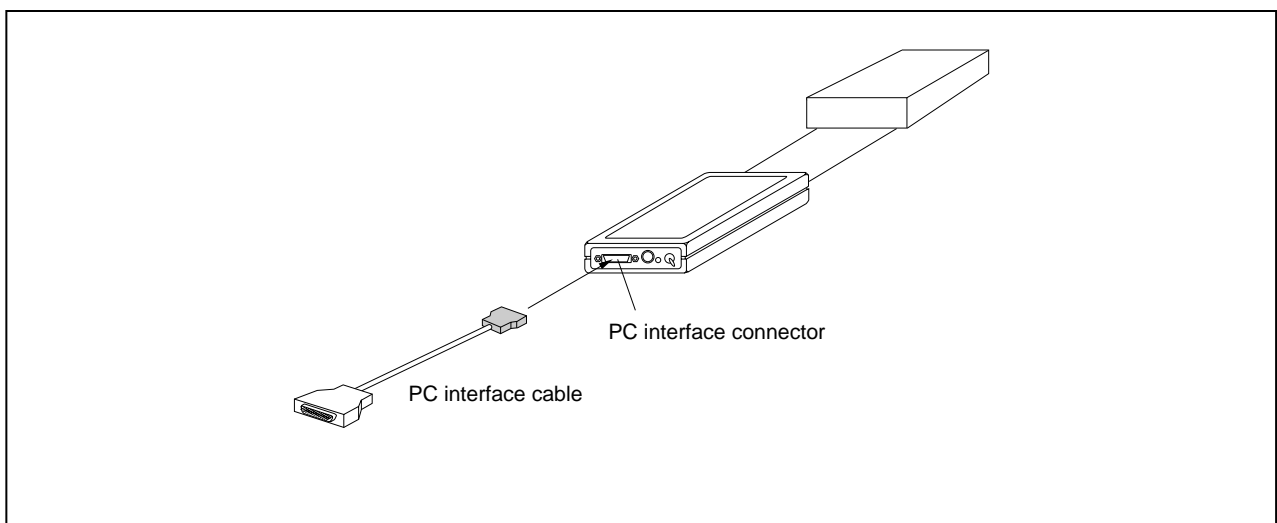

3.3.3 External logic probe connection

When using the external logic probe, connect it to the option board connector.

For details, refer to the option board user's manual.

3.3.4 Additional information

The IE-V850E-MC-A can perform real-time tracing of the emulation CPU bus cycle. In addition, an external logic probe is included with the option board for the following three functions.

For details on its use, refer to the debugger user's manual.

- (1) Any eight signals can be traced in real time.
- (2) Tracer start/stop is enabled using any eight signals.
- (3) Break setting is enabled using any eight signals.

Cautions

1. **Connect the external logic probe only to a TTL-level signal line. The high level and low level cannot be detected correctly if connected to lines other than TTL-level signal lines. Note that the sensor of the IE-V850E-MC-A and option board may be damaged by an excessive voltage level.**

2. **When connecting the external logic probe, use a commercially available IC clip.**

Procedure

- (1) Turn off the power of the target system.
- (2) Turn off the power of the IE-V850E-MC-A.
- (3) Attach an IC clip to any device on the target system.
- (4) Connect the external logic probe to the attached IC clip.
- ★ (5) Connect the GND of the external logic probe to the ground of the target system.

Figure 3-6. External Logic Probe Connection (Using IC Clip)

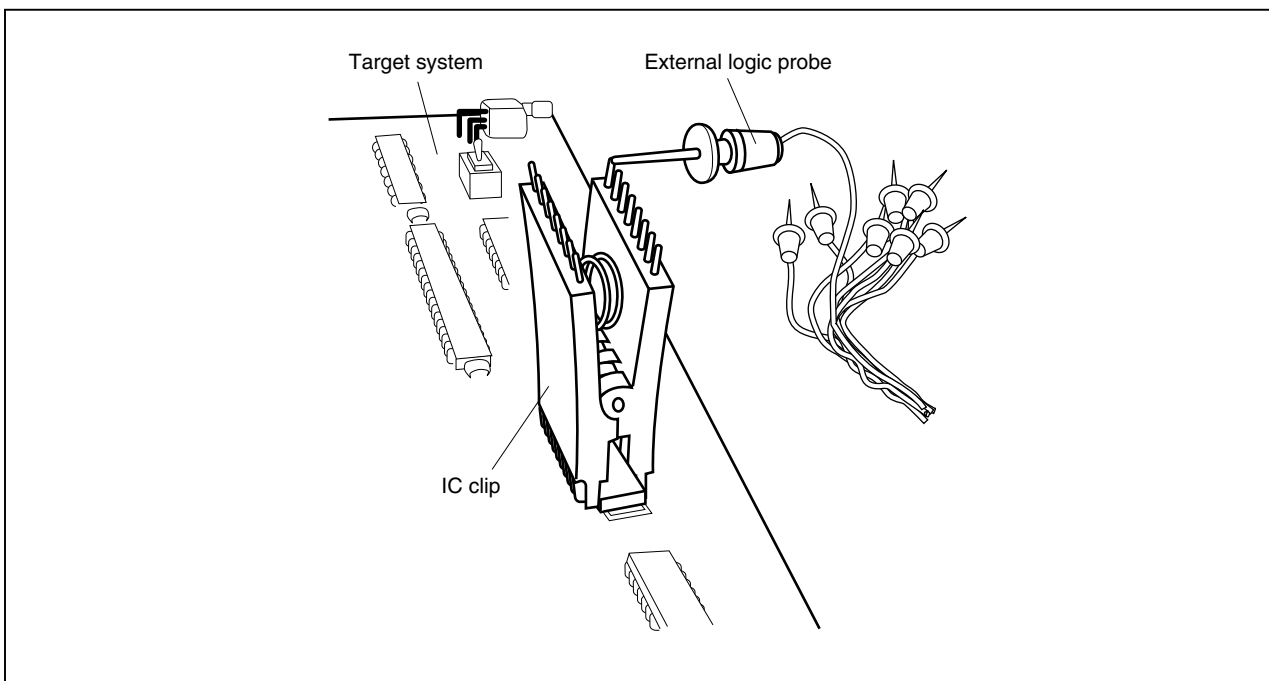

3.4 System Power-On and Power-Off

After connecting the IE-V850E-MC-A and each system component (PC, target system, etc.), start up and shut down the system using the following procedure.

★ **3.4.1 Power-on procedure**

Make sure that the IE-V850E-MC-A is correctly connected to the PC before powering on.

If the IE-V850E-MC-A is powered on using a procedure other than the following one, the IE-V850E-MC-A or the target system may be damaged.

(1) Turn on the power switch of the IE-V850E-MC-A.

Set the power switch to “ON” after connecting the power adapter to the power jack of the IE-V850E-MC-A and the plug to the power outlet.

(2) Turn on the power of the target system.

(3) Start the debugger.

★ **3.4.2 Power-off procedure**

(1) Terminate the debugger.

(2) Turn off the power switch of the target system.

(3) Turn off the power switch of the IE-V850E-MC-A.

★

CHAPTER 4 SHIPMENT SETTINGS

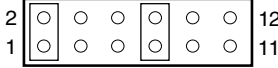
Item	Setting	Description
JP2	 A diagram of a 2x8 jumper block. The top row is labeled '2' on the left and '12' on the right. The bottom row is labeled '1' on the left and '11' on the right. There are two shaded rectangular boxes, one under the first two pins and one under the seventh and eighth pins, indicating they are shorted.	<p>After shipment, the jumper is set with 1 and 2 shorted and 7 and 8 shorted.</p> <p>The setting varies depending on the option board, so for how to set, refer to the user's manual of the option board.</p> <p>Unless specified in the user's manual of the option board, use the jumper with the shipment setting.</p>

★

APPENDIX A DIMENSIONS

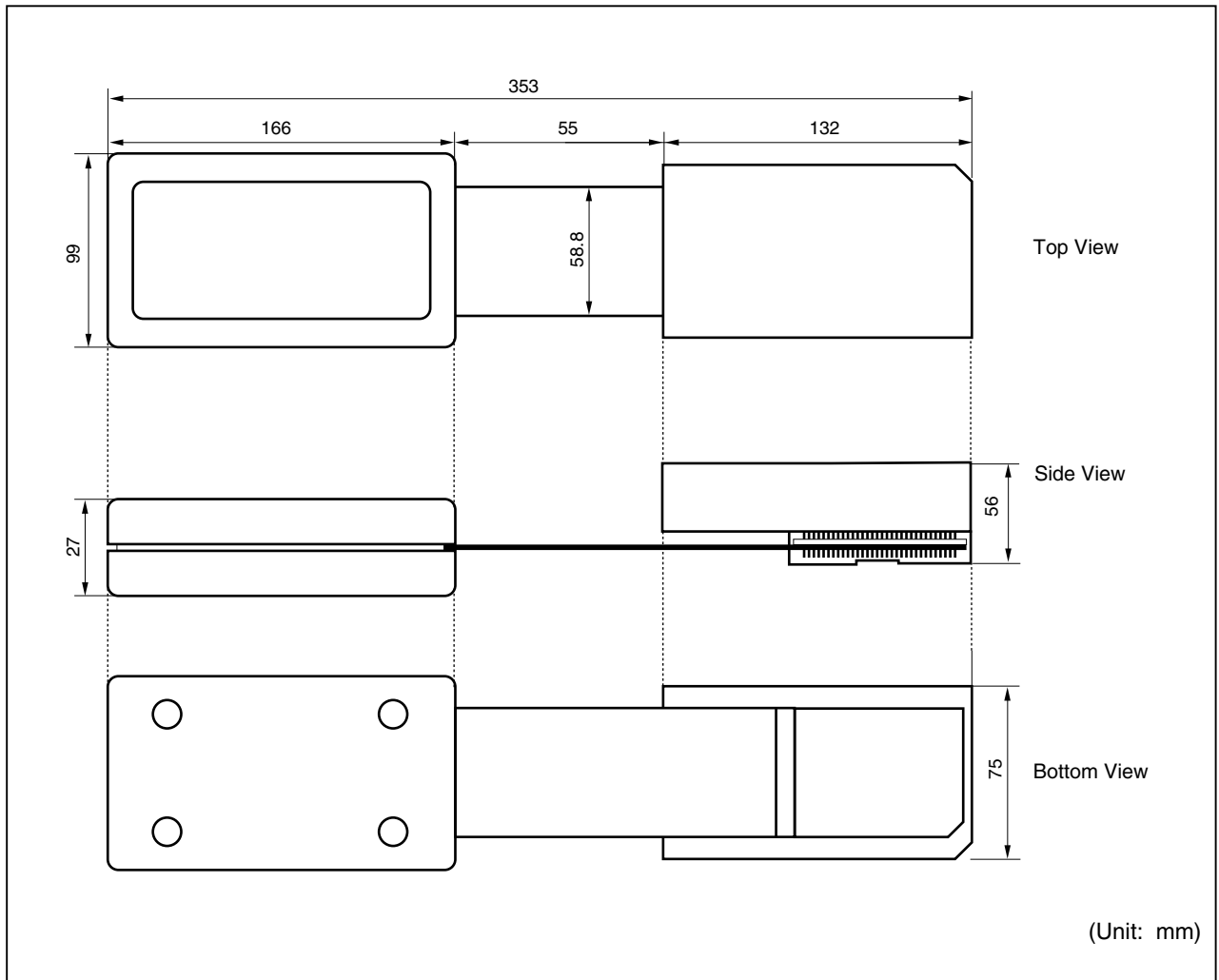

★

APPENDIX B REVISION HISTORY

A history of the revisions up to this edition is shown below. “Applied to:” indicates the chapters to which the revision was applied.

Edition	Contents	Applied to:
2nd edition	<ul style="list-style-type: none"> • Addition of V850E/MA2, V850E/SV2, and V850E/IA2 as target devices • Addition of IE-70000-PCI-IF-A as corresponding PC interface board • Modification of IE-V850E-MC-A shape 	Throughout
	<p>1.1 Hardware Configuration</p> <ul style="list-style-type: none"> • Addition of IE-703166-MC-EM1 and IE-703114-MC-EM1 as option boards • Addition of SWEX-xxxSD-1 as extension probe <p>1.3 Function Specifications</p> <ul style="list-style-type: none"> • Thorough modification <p>Deletion of 1.4 Hardware Configuration</p> <p>1.4 System Configuration</p> <ul style="list-style-type: none"> • Addition of SWEX-xxxSD-1 as extension probe • Addition of descriptions about connector configurations <p>1.6.1 When using IE-V850E-MC-A on a standalone basis for performing software debugging</p> <ul style="list-style-type: none"> • Addition and modification of descriptions <p>1.6.2 When performing hardware debugging with target system</p> <ul style="list-style-type: none"> • Addition and modification of descriptions 	CHAPTER 1 OVERVIEW
	<p>2.2 Pod Part Names and Functions</p> <ul style="list-style-type: none"> • Thorough modification 	CHAPTER 2 PART NAMES AND FUNCTIONS
	<p>3.1.3 Insertion of PC interface board</p> <ul style="list-style-type: none"> • Addition and modification of descriptions <p>3.2 Connection to Target System</p> <ul style="list-style-type: none"> • Modification of descriptions in (1) • Figure 3-1 Connection of Connector for Target Connection and Connector for Emulator Connection divided according to target device <p>3.3.1 Power adapter connection</p> <ul style="list-style-type: none"> • Addition of description to Caution <p>3.3.4 Additional information</p> <ul style="list-style-type: none"> • Addition of description to procedure <p>3.4.1 Power-on procedure</p> <ul style="list-style-type: none"> • Modification of procedure <p>3.4.2 Power-off procedure</p> <ul style="list-style-type: none"> • Modification of procedure 	CHAPTER 3 CONNECTION OF COMPONENTS
	Addition of CHAPTER 4 SHIPMENT SETTINGS	CHAPTER 4 SHIPMENT SETTINGS
	Addition of APPENDIX B REVISION HISTORY	APPENDIX B REVISION HISTORY